



**Thermo Scientific**  
**HAAKE RheoStress 6000**  
modular universal rheometer

**flexible,**  
reliable, precise

**Thermo**  
SCIENTIFIC

# Thermo Scientific rheometer portfolio – an overview

## Which rheometer suits my needs?

We are the world leader in serving science and help our customers solve their analytical challenges from routine tests to complex research and development.

As a pioneer in the field of rheology, we are well-known for our leading Thermo Scientific viscometer and rheometer lines. These instruments precisely analyze a material's rheological properties, temperature-related changes, and the material's processability.

The Thermo Scientific HAAKE RheoStress 6000 rheometer is the latest generation in the successful Thermo Scientific RheoStress series.



### Thermo Scientific HAAKE RheoStress 6000 The modular universal rheometer

Robust, universal, future-oriented, easy to use and equipped with a wide range of accessories as well as an integration of Thermo Scientific HAAKE MARS technology – the HAAKE RheoStress 6000 rheometer combines proven technology with the latest innovations in user-friendly measuring software and firmware making it the ideal rheometer for standard applications in research and development or quality control.

### Thermo Scientific HAAKE Series 1 The versatile rheometer concept

The Thermo Scientific HAAKE Series 1 rheometers are established as application-oriented instruments that can be adjusted to meet individual measuring tasks.

The Thermo Scientific HAAKE RotoVisco 1 is a classical rotational rheometer that offers precise and reliable measurements.

The Thermo Scientific HAAKE RheoStress 1 rheometer is ideal for routine measurements in quality control.



### Thermo Scientific HAAKE MARS The modular rheometer platform for individual needs

The Thermo Scientific HAAKE MARS is one of the most modular high-end rheometer platforms in its class.

The innovative HAAKE MARS system was designed for flexibility and meets the most demanding requirements in research and development with an architecture that

permits integration of custom modules.

The concept is designed to meet today's and future rheology needs while protecting prior accessory investments.

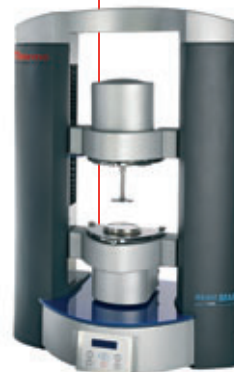

# Combine proven technology with the latest innovation

## Universal Design

### Robust and modular design

Wide range of accessories

- Application-focused measuring cells
- Measuring geometries
- Temperature modules

### Easy to use

Ergonomic electronic box for temperature control modules with integrated valves and innovative display

- Quick connectors for plug & play of temperature modules
- Automatic temperature module recognition
- Rheometer status information

Customizable software for

- Application-specific solutions
- Beginners and professionals

### Future-oriented

- Software upgrades for existing HAAKE RheoStress 6000 rheometer users to benefit from future technological innovations
- Compatible with accessories from the previous HAAKE RheoStress rheometer series
- Adaptable with new accessories to meet evolving application solutions

## The HAAKE RheoStress 6000 benefits from the newest rheometer improvements of the HAAKE MARS

### CR (controlled rate) mode:

Optimized speed control loop and a low motor inertia ( $I=10 \mu\text{Nms}^2$ ) for fast speed steps within a few milliseconds without significant overshoot

### CS (controlled stress) mode:

Advanced patented air-bearing technology plus accurate torque correction (MSC = Micro Stress Control) for measurements at low torque limit

### CD (controlled deformation) mode:

Self-learning deformation control loop based on neural network technology for fast parameter adaptations

### RheoAdaptive Control:

For ultra low rotational speed control down to  $10^{-8}$  rpm and fast response times as well as viscosity measurements over an extremely wide shear rate range up to 11 orders of magnitude in shear rate

### Normal force measurements:

Normal force sensor based on extremely sensitive and robust strain gauges for measurements between -50 and 50 N, to extend measuring capabilities in terms of texture analysis, tackiness or tribology (friction) tests



# Robust design for universal use



Measuring head consisting of:

- Drag cup motor with the lowest available inertia ( $10 \mu\text{Nms}^2$ )
- High resolution optical encoder (12 nrad)
- Patented 4<sup>th</sup> generation air bearing system\*
- Temperature-compensated, normal force sensor\*\*, based on strain-gauge technology for measurements of positive or negative normal forces

Coupling for upper measuring geometries

Holder for temperature control units and application-oriented measuring cells

Electronic control box for temperature modules with integrated valve block and display

Glas plate with high resistance against chemicals for easy cleaning

Compact design by one-column aluminum frame with integrated control and power electronics

\* DE 10 2004 050 753 A1; US 7,181,956 B2

\*\* DE 10 2004 050 753 (patent pending), US 7,187,956

# Thermo Scientific HAAKE RheoWin

## Customizable measuring and evaluation software

### Automatic data quality evaluation

Software tools:

- RheoAdaptive Control
- FDA 21 CFR Part 11 compliance (optional)
- Polymer Software (optional)
  - TTS (time-temperature superposition) to create master curves
  - Spectra
  - MWD (molecular weight distribution)
- Interfacial Rheometry (optional)

### Functionality

- Monitor mode for preliminary testing and presetting the instrument
- Convenient creation and customization of measuring routines using "drag and drop" of measuring and evaluation elements
- Software-guided reproducible sample loading, fully automated measurement, analysis and documentation within one measuring routine
- Real multitasking – simultaneous measurements using several rheometers and data evaluation
- Freely configurable data export (ASCII, MS-Excel®, XML)
- Save graphs in a wide variety of formats (pdf, jpg, etc.)
- Numerous algorithms for data analysis (e.g. interpolation, regression and automated quality control)
- Raw data and numerical values for data evaluation
- Loop programming with break-up criteria



Selection of predefined measurement and analysis elements

### Components

- RheoWin JobManager for fully automated process control ("jobs") of measuring and analysis routines including report printout and/or export
- RheoWin DataManager for interactive evaluation of measured data as well as sophisticated tools for creating reports and generating templates for graphs, tables and screen views
- RheoWin UserManager for comprehensive user management regarding user access control and assignment of specific access rights
- Raw data viewer for verifying validity of oscillation data after the measurement was done

### Customization

- User-defined configuration of paths and subdirectories for data filing
- Push-button selection of one out of 12 languages
- Modular generation of a file name and automated saving in a predefined subdirectory
- Data transfer to ERP and laboratory systems (e.g. SAP®, LIMS, etc.)
- Online display of all corrections to improve data quality (Micro Stress Control)
- Snapshot for quick characterization of an unknown sample
- RheoWizard expert help to set up a measuring routine
- Customizable report templates with custom logos and text



# Temperature modules



## Peltier Plate

for fast temperature changes up to 60 K/min

- Easy exchange of lower plates due to new quick bajonet mounting ring
- Fast heat transfer and very good temperature homogeneity due to low thermal masses

## Electrical Plate

for measurements in a wide temperature range

- Easy exchange of lower plates due to new quick bajonet mounting ring
- In combination with the TM-EL-H active cone heater system a closed chamber with a 360° viewing window is created

## Liquid Plate

for very precise, constant temperature control

- Easy exchange of lower plates due to new quick bajonet mounting ring
- Most reasonably priced unit when using an existing circulator.

## Peltier Cylinder

for fast temperature changes up to 60 K/min

- Easy exchange of cups due to new quick bajonet mounting ring
- Smaller cups and rotors optimized for fast temperature changes
- Can also be used for cone and plate geometries by means of a lower plate adapter
- Switching between a cylinder geometry and a plate or cone geometry is a matter of seconds

## Electrical Cylinder

for very fast temperature changes

- For cylinder geometries or application-focused measuring cells such as pressure cells
- Powerful, with two heating circuits

## Liquid Cylinder

for very precise, constant temperature control

- Larger cups and rotors for low viscosity measurements
- Most reasonably priced unit when using an existing circulator



Temperature module for plate and cone geometries with active cone heater (left: TM-EL-H) and isolated hood (right: TM-IN-H)

## Ease-of-use-Benefits

- Plug-and-play modules with compact design
- Automatic temperature module recognition
- Standardized connections including quick connects for cooling media and electronics
- Very low thermal masses for fast control response time
- Robust design for easy handling and storage
- Easy installation in seconds without adjustment

High-precision production of the lower measuring plate with guide and bayonet ring for simple, plane parallel installation



Universal Peltier temperature module: TM-PE-C with cylinder geometry and with cone / plate geometry; adapter for TMPxx lower measuring plate (shown with plate TMP60)

Temperature module	Tmin °C	Tmax °C	Max. heating rate K / min	Max. cooling rate K / min
Peltier Plate TM-PE-P	-60*	200	60	60
Electrical Plate TM-EL-P	-40*	400**	40**	20
Liquid Plate TM-LI-P	-40*	200*	1-5*	1-5*
Peltier Cylinder TM-PE-C	-40*	200	60	60
Electrical Cylinder TM-EL-C	-20*	200 (300***)	10	10
Liquid Cylinder TM-LI-C	-20*	180*	1-5*	1-5*

\* Depending on the cooling medium and circulator, \*\* In combination with hood, \*\*\* Using suitable geometries, e.g. for pressure cell

# Measuring geometries



## Comprehensive selection of measuring geometries for a wide variety of applications

We offer concentric cylinders, plate/plate and plate/cone measuring geometries as well as disposable and custom designs:

- in multiple sizes
- of various materials
- with different surfaces

The standard measuring geometries are made of titanium and designed for use with a solvent trap, for preventing the sample from drying out.

For plate and cone rotors lower plates are available with the same

- size
- material
- surface

This ensures ideal measuring conditions, such as optimal sample filling.

## Selection of measuring geometries

Plates, cones, cylinders with helical grooving to prevent sedimentation and vane rotors



## Sample hoods

Sample hoods for preventing heat loss and solvent evaporation as well as minimizing the temperature gradient are available in three different versions:

- Two part POM (Polyoxymethylene) version for temperatures up to 120 °C
- Insulated sample hood TM-IN-H with Ampcoloy® inlet and Teflon® insulation for very fast heat transfer in a temperature range from -40 °C up to 200 °C
- Unique transparent glass cover for observing the sample during the measurement, for temperatures up to 400 °C

### Common features for all hoods:

- Integrated inner and outer solvent trap for all geometries!
- Small enclosed volume
- Automatically centered and closed by lower plate
- Inlet for nitrogen gas to create inert atmosphere

## Double-cone geometry for measurements on low viscosity samples

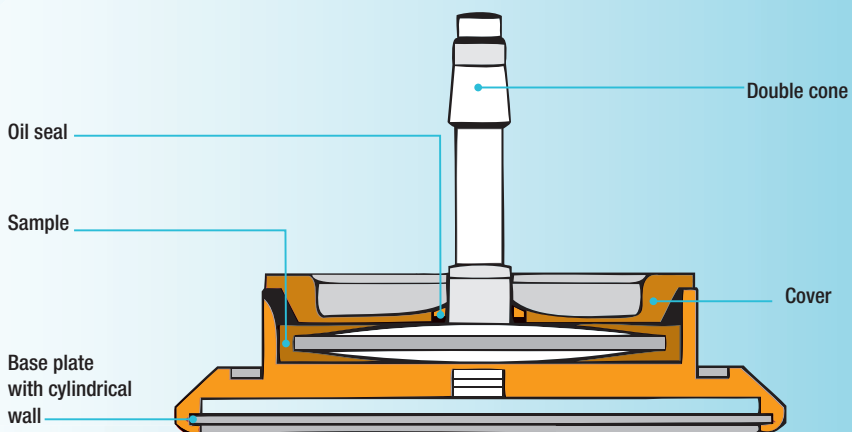

Rotor with diameter to fit lower plate for optimized gap filling and sample cover (glass or POM) with inert gas connection and integrated solvent trap

# Application solutions



## Food

Mouthfeel is a crucial property of any food or beverage. To know the visco-elastic properties linked to the mouthfeel is essential for development, production and quality control.

In addition, the rheological properties determine how to run important steps of the production process like pumping, mixing, spraying and filling with best efficiency.

## Paints, inks and coatings

The requirements and demands placed on paints, inks and coatings are constantly increasing. Eco-friendly technologies and products are growing in importance, e.g. water as a diluting agent or UV irradiation as a fast, energy-saving cross-linking method.



## Petrochemicals

Every crude oil behaves differently depending on its composition, temperature and pressure.

During exploration, recovery, and transport the viscosity of crude oil and the effectivity of individually composed additives are crucial information to manage an oilfield or operate a pipeline at top performance with minimum costs.

## Pharmaceuticals and Cosmetics

Rheological properties are essential for the reduction of time to market, optimization of processing, quality control and documentation. The HAAKE RheoStress 6000 rheometer enables high throughput measurements with just a small sample quantity for formulation development, process development and stability testing for a wide range of pharmaceutical and cosmetic products.



## Polymers

Understanding the basic polymerization processes and processability limits of your product as well as its visco-elasticity that correlates with its molecular weight and molecular weight distribution is key to custom-tailor your polymer and plastics application with respect to energy and time efficiency as well as sustainability. The HAAKE RheoStress 6000 rheometer is designed to support you in every phase of your multi-layered processes.



### Selected Accessories

- Adaptable holder for various food containers to accelerate testing
- Special vane rotors for samples containing bigger pieces like fruits or kernels of rice
- Tribology cell e.g. for the taste of chocolate
- 3-point-bending/breaking accessory e.g. for chocolate or cookies
- Pressure cells up to 300 °C and 700 bar to simulate cooking processes

The flow behavior of these products is highly complex, but can be controlled when the relevant parameters are known. The HAAKE RheoStress 6000 rheometer supports you in every phase of your multi-layered process.

### Selected Accessories

- Sample covers, including solvent traps to prevent solvent loss
- Double cone to measure low-viscosity without any edge effects
- Plate/ring measuring geometry for special curing reactions
- Disposable plate/plate geometries to eliminate time consuming cleaning
- UV measuring cells for the investigation of UV-curing reactions
- High shear measuring cell for very high shear rates



### Selected Accessories

- Pressure cells up to 300 °C and 700 bar
- Hastelloy® pressure cells for aggressive liquids
- Pump for pressurization and pressure controller for isobaric tests
- Special vane rotors for samples containing sand or stones
- Tribology cell for lubrication and abrasion tests
- SHRP cell for the characterization of bitumen



### Selected Accessories

- 21 CFR Part 11 tool with electronic signature and audit trail
- Peltier temperature control for thermal stability testing or e.g. investigation of sol/gel transitions
- Submersion flow cell e.g. for testing interactions between creams and ointments with human skin or bandage adhesion when subjected to skin secretion
- Universal container holder for measurements in original jars or pots



### Selected Accessories

- Electrically heated plate/plate geometries up to 400 °C
- Disposable plate/plate geometries to eliminate time consuming cleaning
- UV measuring cells for the investigation of UV curing reactions
- Tribology cell to determine friction, lubrication and wear
- HAAKE RheoWin modules for TTS, spectra and MWD calculation

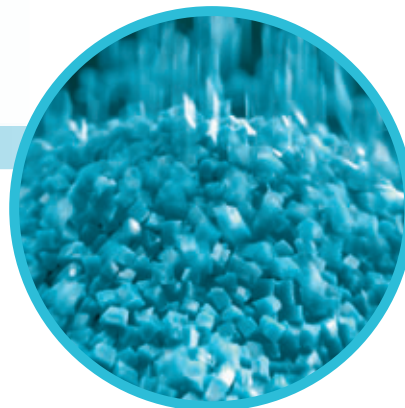

# A selection of application-oriented



## Pressure cells

Different versions of pressure cells for pressures up to 700 bar and 300 °C are available and can be used with coaxial cylinder geometries, double gap or vane rotors. A Hastelloy® version can be used with corrosive samples.

- **Application examples:**  
Crude oil, drilling fluids, food



## Measuring cell for construction materials

A patented \* special measuring cell with a flexible profile for measurements on building materials is offered. Thanks to the interchangeable profile lamellas the measuring cell can be easily and quickly adapted to new materials. The design avoids slippage layer formation.

- **Application examples:**  
Cement pastes and mortars, samples with big particles

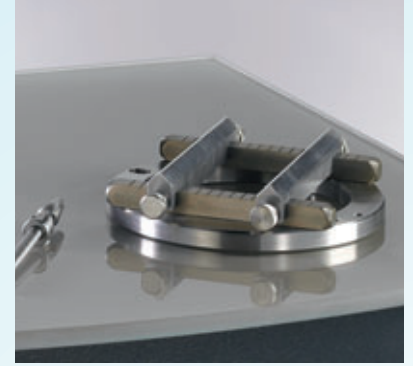

## 3 point bending tool

Sample fixture to investigate the bending and breaking behavior of a range of materials.

- **Application example:**  
Food (chocolate, cookies)



## UV-curing cells

For tests on UV-curing materials. UV cells are available as a standard version and as an individual measuring cell with freely configurable distances for optical components such as light guides, condensers and glass plates

- **Application examples:**  
Coatings, dental material, contact lenses



\* DE 10 2006 022316, US 7,673,499

# accessories

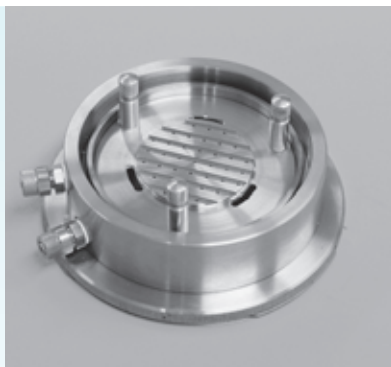

## Submersion flow cell

Cell filled with fluid for testing interactions between creams and salves with human skin or bandage adhesion when subjected to skin secretions

**Application example:**  
Cosmetic products, plasters, construction materials, coatings

## Universal holder for individual containers

Holder with individually adjustable clamps for sample containers like glass jars, cans, beakers and cups.

**Application examples:**  
Paints, inks, food



## Tribology cell

Measuring cell for friction tests to determine the tribological behavior of material combinations with or without lubricants

**Application examples:**  
Oils, lubricants



## Interfacial rheology

Du Noüy ring to determine the viscoelastic properties of interfaces

**Application examples:**  
Emulsions, foam, multi layer products (e.g. curtain coating)



# Technical

## specifications

Min. torque rotation CS	200 nNm
Min. torque rotation CR	200 nNm
Min. torque oscillation CS	200 nNm
Min. torque oscillation CD	200 nNm
Max. torque	0.2 Nm
Motor inertia	10 $\mu\text{kgm}^2$
Angular resolution	12 nrad <sup>(a)</sup>
Min. angular velocity CS	$10^{-7} \text{ min}^{-1}$
Min. angular velocity CR	$10^{-5} \text{ min}^{-1}/10^{-7} \text{ min}^{-5}$ (e)
Max. angular velocity	1500, 4500 $\text{min}^{-1}$ (b)
Min. oscillation frequency	$10^{-5} \text{ Hz}$
Max. oscillation frequency	100 Hz
Min. Normal force	0.01 N
Max. Normal force	50 N <sup>(c)</sup>
Normal force resolution	0.001 N
Min. lift speed	0.2 $\mu\text{m/s}$
Max. lift speed	7 mm/s
Lift positioning accuracy	0.5 $\mu\text{m}$
Temperature range	-60 to +400 °C <sup>(d)</sup>
Dimensions (W x D x H)	400 x 400 x 780 mm
Weight	42 kg

(a) internal resolution (b) high shear option (c) in both positive and negative direction  
(d) depending on temperature control unit (e) RheoAdaptive Control Option

# Service

**REQUEST, NOW!**  
INFO.MC.DE@THERMOFISHER.COM



## Custom services

We are committed to customer support, including specific service products, short response times, and customer-specific solutions. To quickly and flexibly meet our customers' requirements, we offer a comprehensive range of services.

## Application laboratories and support

Our fully equipped laboratories reflect our application expertise and commitment to innovation. Our laboratories are in constant demand for testing customer samples and developing and optimizing pioneering applications. We also provide a broad range of product and application solutions and our application specialist team is on hand to answer your questions.

## Comprehensive knowledge base

We offer a wide range of literature to help you enhance your knowledge on rheology as well on applications solutions that help you in your daily work.

Selected product information and application notes:

- V157 Rheological analysis of powder coatings
- V216 Rheology of pharmaceutical suspensions
- V222 Breaking strength of chocolate
- V233 Pressure cell for sensitive measurements
- P23 Measuring cell for tribological tests
- P26 Du Noüy ring for interfacial rheology

## Seminars and training courses

Customers are offered a comprehensive training program and selected courses in our international training center in Karlsruhe, Germany. Basic and advanced rheology seminars and training on special applications are held worldwide. In-house seminars are also offered to our customers. For more information visit [www.thermoscientific.com/mc\\_seminar](http://www.thermoscientific.com/mc_seminar).

## Thermo Scientific Service à la Carte

We offer a wide range of professional services to a variety of industries to help our customers improve their productivity and decrease costs. Individual solutions to support our customers and maintain their instruments are a standard service. Additional service packages, warranty extensions or premium service packages, which can be bundled, allow our customers to plan and budget for maintenance and service support. We also offer custom-designed service programs that support IQ/OQ requirements for example. All services are provided by skilled and certified service engineers.



## The Service Module Solution

## About Thermo Fisher Scientific

Thermo Fisher Scientific Inc. (NYSE: TMO) is the world leader in serving science. Our mission is to enable our customers to make the world healthier, cleaner and safer. With revenues of nearly \$11 billion, we have approximately 37,000 employees and serve customers within pharmaceutical and biotech companies, hospitals and clinical diagnostic labs, universities, research institutions and government agencies, as well as in environmental and process control industries. We create value for our key stakeholders through two premier brands, Thermo Scientific and Fisher Scientific, which offer a unique combination of continuous technology development and the most convenient purchasing options. Our products and services help accelerate the pace of scientific discovery, and solve analytical challenges ranging from complex research to routine testing to field applications. Visit [www.thermofisher.com](http://www.thermofisher.com).

Thermo Fisher Scientific, one of the pioneers in rheology, successfully supports a wide range of industries with its comprehensive Thermo Scientific material characterization solutions. Material characterization solutions analyze and measure viscosity, elasticity, processability and temperature-related mechanical changes of plastics, food, cosmetics, pharmaceuticals and coatings, chemical or petrochemical products, plus a wide variety of liquids or solids. For more information, please visit [www.thermoscientific.com/mc](http://www.thermoscientific.com/mc).



© 2011/07 Thermo Fisher Scientific Inc. · 623-2103 · Copyrights in and to all photographs of instruments, accessories and red fruit jelly are owned by Thermo Fisher Scientific. Copyrights in and to all other photographs are owned by a third party and licensed for limited use only to Thermo Fisher Scientific by iStockphoto. This document is for informational purposes only. Hastelloy is a registered trademark of Haynes International, Ltd. Ampcoloy is a registered trademark of MatWeb, LLC. Teflon is a registered trademark of DuPont. Specifications, terms and pricing are subject to change. Not all products are available in every country. Please consult your local sales representative for details.

### Material Characterization

#### Benelux

Tel. +31 (0) 76 579 55 55  
[info.mc.nl@thermofisher.com](mailto:info.mc.nl@thermofisher.com)

#### China

Tel. +86 (21) 68 65 45 88  
[info.mc.china@thermofisher.com](mailto:info.mc.china@thermofisher.com)

#### France

Tel. +33 (0) 1 60 92 48 00  
[info.mc.fr@thermofisher.com](mailto:info.mc.fr@thermofisher.com)

#### India

Tel. +91 (20) 6626 7000  
[info.mc.in@thermofisher.com](mailto:info.mc.in@thermofisher.com)

#### Japan

Tel. +81 (45) 453-9167  
[info.mc.jp@thermofisher.com](mailto:info.mc.jp@thermofisher.com)

#### United Kingdom

Tel. +44 (0) 1606 548 100  
[info.mc.uk@thermofisher.com](mailto:info.mc.uk@thermofisher.com)

#### USA

Tel. +1 603 436 9444  
[info.mc.us@thermofisher.com](mailto:info.mc.us@thermofisher.com)

#### International/Germany

Dieselstr. 4  
76227 Karlsruhe  
Tel. +49 (0) 721 4 09 44 44  
[info.mc.de@thermofisher.com](mailto:info.mc.de@thermofisher.com)

[www.thermoscientific.com/mc](http://www.thermoscientific.com/mc)

**Thermo**  
SCIENTIFIC

Part of Thermo Fisher Scientific